

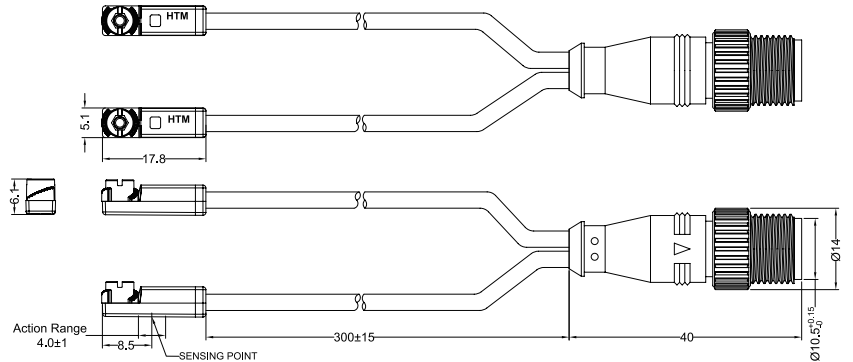

Note: The product images shown may change over time as products are updated.

Dimensions



Part Number

PCDT-D06/18S-A4S0.3/P12

Features

HTM Sensors Pneumatic Cylinder Sensors are built to provide reliable operation of pneumatic cylinders for motion control applications in any manufacturing environment. HTM Sensors provides easy mounting T-slot, C-slot, Dovetail and Tie-rod mounting options to match the design of most commonly used pneumatic cylinders.

Technical Data

Body Style	T-Slot
Mounting Style	Drop-In
Magnet Requirement	60 Gauss
Output Type	2x Smart Select NPN/PNP
Output Function	Normally Open
Connection	Quick Connect
Connector Type	M12 A-coded 4 pin
Operating Voltage	5-30 V DC
Switching Frequency	900 Hz
Operating Temperature	-10 C to +70 C
Current Consumption	<= 2.5 mA @ 24 V DC per sensor head
IP Rating	IP67
Vibration Rating	9G
Shock Rating	50G
Body Material	Polycarbonate
Short Circuit Protected	No
Reverse Polarity Protected	Yes
Max Current	100 mA per sensor head
Leakage Current	< 0.01 mA per sensor head
Weld Field Immune	No
Weld Spatter Resistant	No

Connection

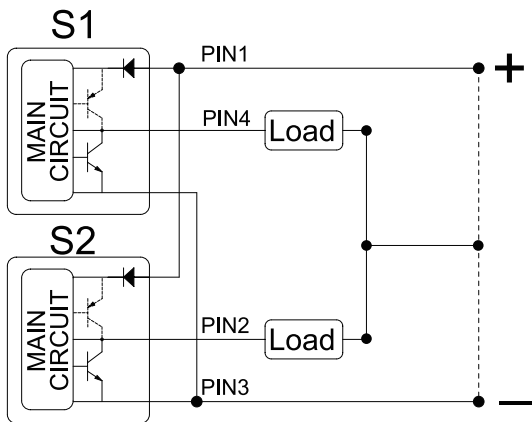

In the USA: 1889 Maryland Ave., Niagara Falls, NY 14305  
 In Canada: 3419 Mainway, Burlington, ON L7M 1A9  
 Toll Free: 1-800-644-1756 • Fax: 888-283-2127  
 service@htmsensors.com